

[INSTALLATION MANUAL]

SUN-GRID



Table of contents

1 Introduction	3	Variation for plain tile roof covering	10
1.1 Overview	3	Variation for shingle/slate roof covering	10
1.2 Intended use	3	6.2 Installing hanger bolts	11
1.3 Standards and technical directives	3	6.3 Installing clamp-on roof hooks	11
1.4 About this manual	3		
2 Safety	4	7 Install the system	12
2.1 Basic safety instructions	4	7.1 Installation procedure	12
2.2 Working on roofs	4	7.2 Quickstone and X-Stone	12
2.3 Warnings	4	Installing the Quickstone	12
2.4 Responsibilities of the operator	4	Installing the X-Stone	12
		7.3 Installing the base rails	13
3 Technical Description	5	Fixing the base rails	14
3.1 System overview	5	Aligning the rails	14
3.2 Scope of delivery	6	Inter-connecting base rails	14
		Installing telescoping end-pieces (optional)	15
4 Designing the module field	7	7.4 Installing the modules	16
		Installing anti-slip protection	17
5 Important installation instructions	8	Fixing the outer modules of each row	17
5.1 Operating conditions	8	Fixing the inner modules of each row	17
5.2 Preparation	8	Installing further rows of modules	18
5.3 Tools	8		
6 Installation of roof connections	9	8 Variation for landscape installation of the modules	19
6.1 Installing the standard roof hook 170	9	8.1 Installing base rails vertically	19
Variation when using roof hooks for heavy snow	10	8.2 Installing cross rails	19

1 Introduction

1.1 Overview

The Sun-Grid is a robust, long-life mounting system for photovoltaic modules on pitched roofs. It comprises aluminium rails, roof connections and all necessary small parts to ensure a safe installation. The proven Quickstone profile nut makes installation quick and easy. With Sun-Grid modules can be mounted in both landscape and portrait orientation.

1.2 Intended use

The mounting system Sun-Grid is to be used for the roof mounting of photovoltaic modules only. SOLFEX is not liable for damages resulting from failing to comply with the installation instructions, particularly the safety instructions, as well as misuse of the product.

1.3 Standards and technical directives

When planned correctly, Sun-Grid fulfills the following standards and technical directives:

| Eurocode 9 - DIN V ENV 1999 Design of aluminium structures
| DIN 1055 Actions on structures - Part 100: Basis of design, safety concept and design rules

1.4 About this manual

Subject

This manual details the installation and assembly of the Sun-Grid photovoltaic mounting system.

User group

The manual is intended for qualified personnel with a basic knowledge of mechanics, hand tools and mechanical skills.

Signposts

The following will assist you in finding your way around in this manual:

Headers

The headers display the heading of the current chapter.

Footers

The footers display the product name, the name of the document and the page number.

Text markups

Labels in the text are printed in **bold**, brand and company names in *italics*, item numbers from the illustrations are depicted in a text box as (1), (2), etc.

Pictographs



Identifies background and additional information for processes.



Tips and tricks

Facilitate installation

2 Safety

2.1 Basic safety instructions

The following basic safety instructions and the warning notes are an essential part of this manual and are of fundamental importance for handling the product.

Regardless of the certified structural analysis, it must be ensured prior to every installation that the product meets the static requirements on site according to the local jurisdiction having authority for such installation.

2.2 Working on roofs

When working on roofs, note the following instructions:

- | Pay attention to accident prevention regulations for working on roofs. If appropriate, use a barrier to protect against falling parts.
- | In line with accident prevention regulations, work on roofs should be carried out using safety harnesses for individuals or safety scaffolding.
- | Observe the relevant local safety regulations.
- | Before stepping on to the roof, check the load-bearing capability of all parts which are under stress.
- | Use fall protection.
- | Use protective equipment to guard against falling even when carrying out short jobs.
- | Do not carry materials on to the roof via ladders, but rather use suitable lifting gear.

2.3 Warnings

The warning notes used in this manual identify safety related information. They consist of:

- | Warning symbol (pictograph)
- | Indicator word to denote the danger level
- | Information about type and source of the danger
- | Information about possible consequences if the danger is not observed
- | Measures for avoiding the danger and for preventing injuries or property damages

The heading of the warning notes identifies one of the following danger levels:



DANGER

Denotes a major risk, failure to observe which could lead to serious injury or death.



WARNING

Denotes a potentially dangerous situation which may lead to moderate to serious physical injury and property damage.



CAUTION

Denotes a potential risk which may lead to physical injury and property damage.

2.4 Responsibilities of the operator

Modifications to equipment may be performed only by authorized personnel.

The operator of the system has the following safety related responsibilities:

- | Performing recommended maintenance work.
- | Ensuring that the installation of the frame is performed only by qualified personnel with adequate skill and knowledge.
- | Ensuring that the assigned installation personnel can evaluate the work assigned and recognize possible dangers.
- | Ensuring that the installation manual is available during the installation. The installation manual is part of the product.
- | Ensuring that the installation manual and particularly the safety instructions are read and understood by the authorized installation personnel prior to beginning the work.
- | Ensuring that work site safety regulations and requirements are observed.
- | Ensuring that suitable

3 Technical Description

3.1 System overview

All components of the system are listed below. The version and quantities of the parts can vary, depending on

- | Type of roof,
- | Type of module,
- | Number of modules,
- | Site specifics.

- (1) Base rail
- (2) Joiner piece
- (3) Inter-module clamp
- (4) Roof hook
- (5) Module end clamp
- (6) Telescoping end piece (optional)

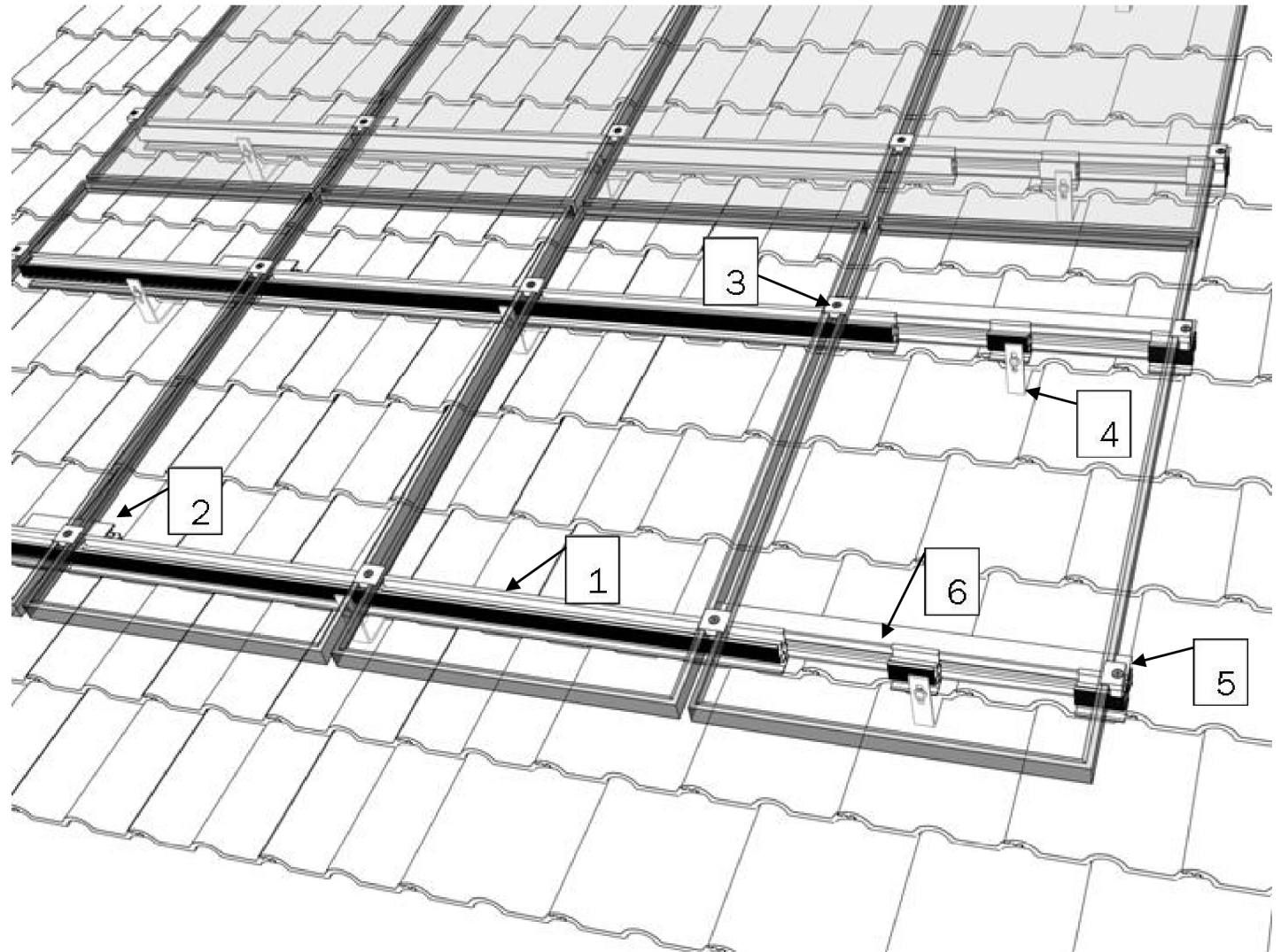

3.2 Scope of delivery

All system parts and requisite small parts which are required for installation are included in the delivery. The precise scope of supply will depend on the size and number of PV modules which you specify when ordering.

- (1) Roof hook 170
- (2) Roof hook for heavy snow
- (3) Roof hook for plain tiles
- (4) Roof hook for Slate/Shingles
- (5) Clamp-on roof hook
- (6) Hanger bolt
- (7) Base rail 13/58, 19/63 and 25/65
- (8) Base rail 7/49
- (9) Joiner pieces 13/58, 19/63 and 25/65
- (10) Joiner piece 7/49
- (11) Telescoping end pieces 13/58, 19/63 and 25/65
- (12) Telescoping end piece 7/49
- (13) Inter-module clamp
- (14) Module-end clamp (for frame heights 24.5 mm to 51 mm)
- (15) Module-end clamp (for frame heights 35, 43, 46, 50 mm)
- (16) Inter-laminate clamp (for laminates 6 to 8 mm thick)
- (17) Laminate-end clamp (for laminates 6 to 8 mm thick)

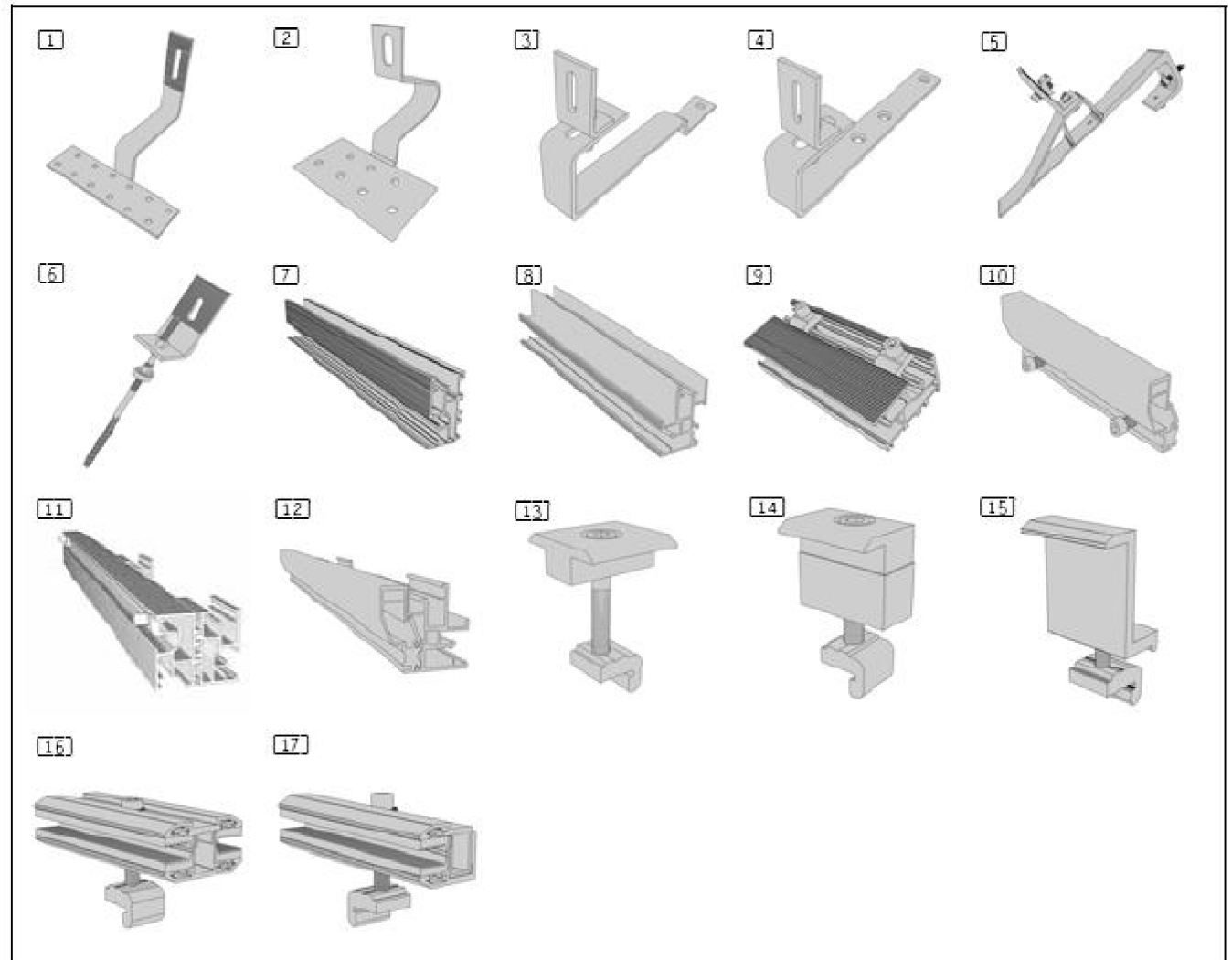

4 Designing the module field

Below, the distances between roof connections for a portrait installation are specified. Clamp-on roof hooks, roof hooks and hanger bolts need to be installed in specific distances, depending on the distance of rafters and the static conditions.

(1) Height of the module field:
module height x number of modules vertically

(2) Width of the module field:
number of modules horizontally x (width of the module + 18 mm) + 32 mm

(3) Distance between roof connections vertically (according to the clamping points pre-defined by the module producer): Quarter-points of the modules, about 1/2 of module height.

(4) Distance between roof connections horizontally:
Depending on the distance between rafters and on the static requirements*

(5) Distance between modules: 17 mm

When positioning the modules, please take into consideration

- | That the values above are
- | That dimensions of tiles or other roof covering and the position of the rafters define the precise actual horizontal distance between roof connections
- | That the distance between roof laths defines the precise actual vertical distance between roof connections.

* The configuration must be in accordance with the local conditions and with DIN 1055 parts 4 and 5 / Eurocode 9 DIN V ENV

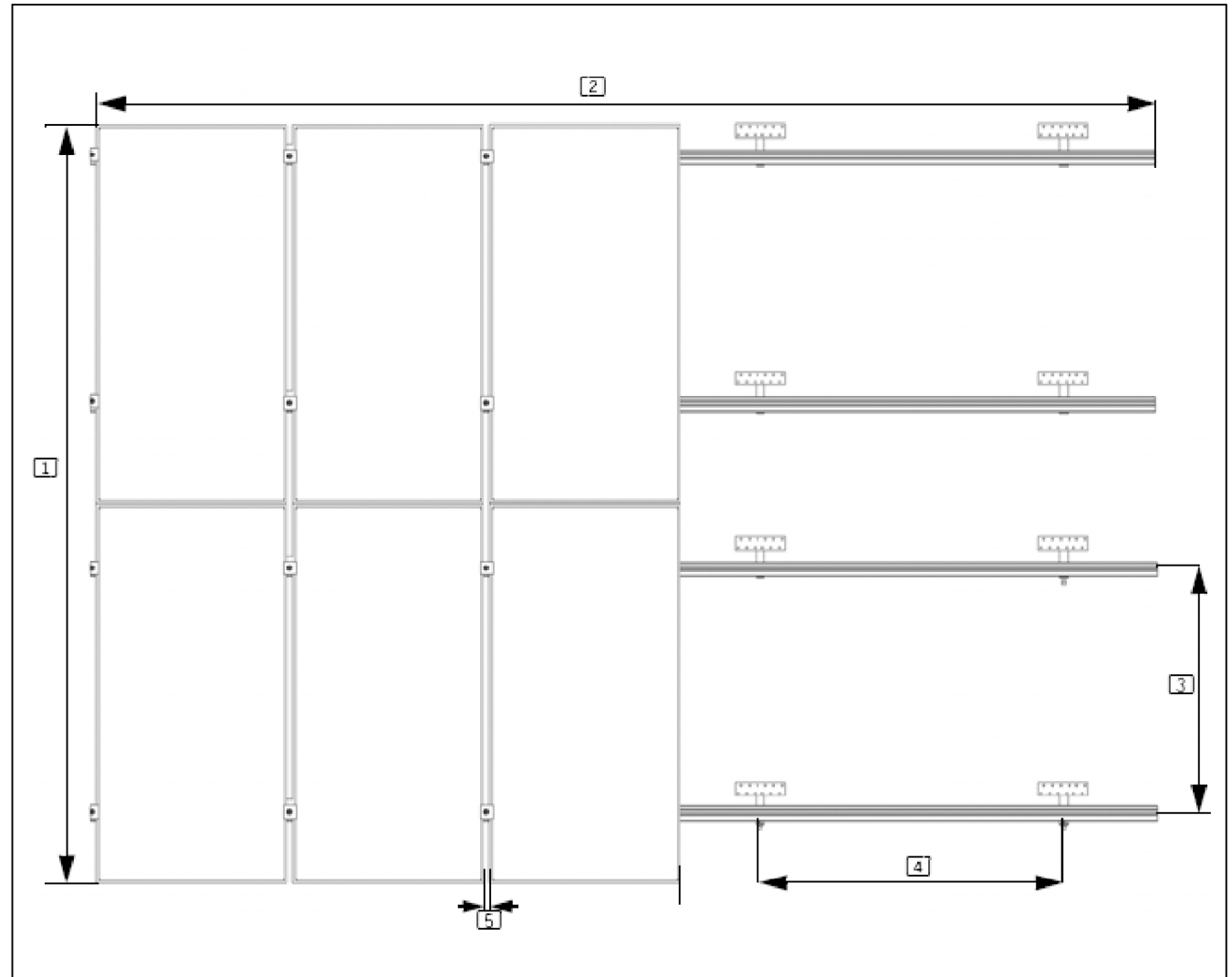

5 Important installation instructions

5.1 Operating conditions

The various components of the on-roof system Sun-Grid can withstand different maximum charges. Therefore, the exact components for a project need to be checked as to their compliance with the local standards and regulations for each project. This can easily be done, for example, by way of the Sun-Grid calculation tool.

5.2 Preparation

It is recommended to familiarize yourself with the conditions on site before ordering Sun-Grid, especially regarding

- | The roof construction (including isolation)
- | Dimensions and quality of roof laths and rafters
- | Type, shape and material of the roof covering

5.3 Tools

The following tools are required for the installation:

- | 6 mm Allen key
- | Cordless drill
- | Open-end spanner (13)
- | Torx-30 (AW 30) Bit
- | Angle grinder with stone disk
- | Cord
- | Spirit level
- | rule
- | If necessary, timber to shim the roof hooks
- | Hoisting gear
- | Vacuum lifting pads
- | Power drill (as necessary)

6 Installation of roof connections



WARNING

Working on the roof

During work on the roof, parts can drop down or persons may fall off.

- | Secure yourself against falling.
- | Do not remain in the danger area.
- | Wear a hard hat.
- | After completing the installation, check that the system and the PV modules are securely fastened.



CAUTION

Damage to tiles through stepping on roof hooks

Do not use fitted roof hooks as a ladder, as this extreme point load could damage the tile below.



CAUTION

Observe minimum edge distances

- Screws fixed too close to the edges of rafters can rip out.
- | Do not fix any screws closer than 30mm to the edge of rafters.
 - | Pre-drill holes when using screws with a diameter >6mm.

Depending on the type of roof covering, different roof connections must be used. The type of roof connection included in your delivery depends on your order.

6.1 Installing the standard roof hook 170

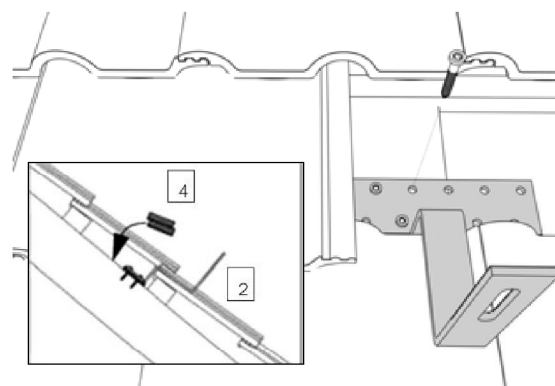

- (1) 3x wood screw (6 x 80 mm)
- (2) Rafter
- (3) Standard roof hook 170
- (4) Wood plates to shim roof hooks, if necessary



CAUTION

Material damage through faulty installation

The roof hook must not press against the tiles to avoid damaging the tiles. If necessary:

- | Shim roof hook with wooden plates, so that the roof hook does not touch the underlying tile.
- | If necessary, use an angle grinder or hammer to cut a recess in the tile that covers the roof hook so that the tile lies flat on the surface.

Installation:

- | Remove the roof tiles at the marked positions or, if possible, simply push them up.
- | Position the roof hooks above the low parts of the tiles
- | Fix the roof hooks to the rafter using three 6 x 80 mm wood screws.

Variation when using roof hooks for heavy snow

| The roof hook for heavy snow is installed in the same manner as the standard roof hook. However, it is fixed with 2 hex head screws 8x80 mm and 2 washers.

Variation for plain tile roof covering

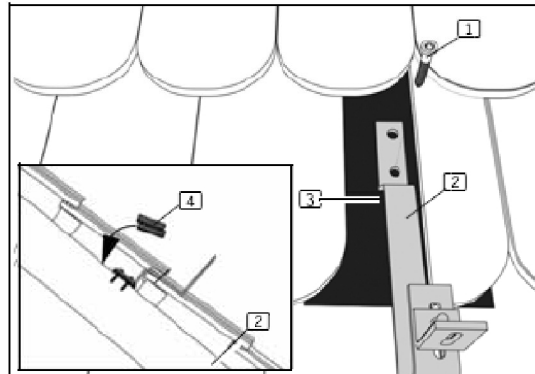

- (1) 2x wood screw (6 x 80 mm)
- (2) Roof hook for plain tiles
- (3) Sheet of titanium zinc
- (4) Wood plates to shim roof hooks, if necessary



CAUTION!

Damage to the building through leakage

Without appropriate flashing of the roof hook, the roof can leak.

| Use a zinc metal sheet with at least 20mm around the recess in the tiles underneath the roof hook.

Installation:

| Cut a recess into the tiles around the position of the roof hook.

| Cut titanium zinc metal sheets to fit and install them under the roof hooks.

| Fix the roof hooks to the rafter using two 6 x 80 mm wood screws.

Variation for shingle/slate roof covering



CAUTION!

Damage to the building through leakage

Without appropriate flashing of the roof hook, the roof can leak.

| Use a zinc metal sheet with at least 20 mm around the recess in the tiles underneath the roof hook.

Installation:

| The roof hook for shingles/slate is installed in the same manner as the roof hook for plain tiles. However, it is fixed with 3 wood screws 6x100 mm.

6.2 Installing hanger bolts

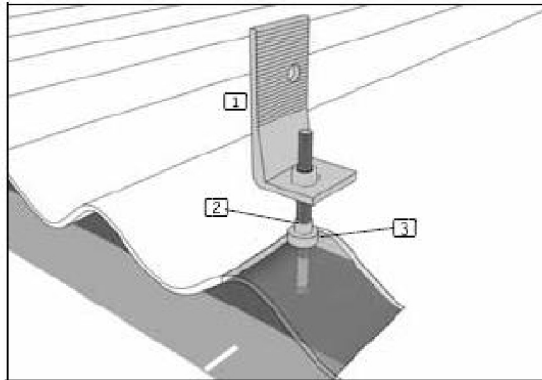

- (1) Hanger bolt with L-bracket
- (2) Sealing washer
- (3) Nut



CAUTION

Damage to the building through leakage

Inappropriately fixed hanger bolts can cause leakage.

| Never position hanger bolts on the low parts of the corrugated sheets.



CAUTION

Observe minimum edge distances

Hanger bolts fixed too close to the edges of purlins can rip out.

| Observe a minimum distance of 5xd to the edge of the purlin when installing hanger bolts.

| Pre-drill holes when using bolts with a diameter > 6mm.

Installation:

| Drill through the roof cladding at the planned location.

| Screw the hanger bolts into the purlins.

| Press the sealing washer onto the drill hole and fix it with the nut without further damaging the sheeting. The tightening torque depends on the type of roof sheeting.

6.3 Installing clamp-on roof hooks

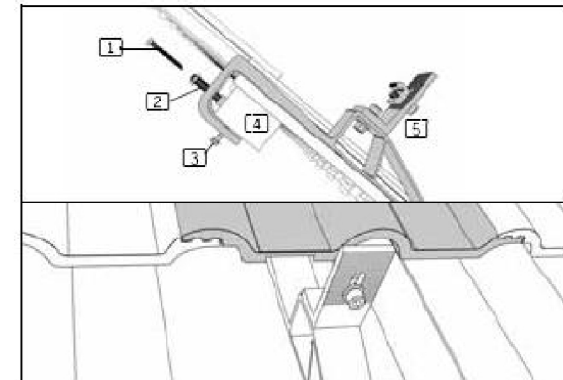

- (1) Spax wood screw (optional)
- (2) Spacer bolt
- (3) Fixing bolt
- (4) Roof lath
- (5) Clamp-on roof hook with L-bracket



CAUTION

Damage to the isolation

With some roof constructions, the fixing bolt can damage the isolation of the roof.

| If necessary, take out the fixing bolt and use the Spax wood screw to fix the roof hook to the lath.

Installation

| Position the roof hook above the low part of the tile and clamp it onto the roof lath.

| Adjust the spacer bolt so that the roof hook does not touch the small side of the tile (min. 2mm distance)

| Tighten the fixing bolt by hand, so that the roof hook can no longer move under wind suction conditions.

| If necessary, use an angle grinder or hammer to cut a recess in the tile that covers the roof hook so that the tile lies flat on the surface

7 Install the system

7.1 Installation procedure

The following pages list the individual steps for installing the Sun-Grid in the correct sequence.

The pages feature three columns. Each column represents a complete sequence of actions. The sequence of actions consists of an illustration, the corresponding steps and additional information and safety instructions.

7.2 Quickstone and X-Stone

During the installation of SolarConstruct , Quickstones are used.

The Quickstone is a special nut used to connect several parts of the Sun-Grid . The only tool needed for installation is a 6 mm Allen key. The Quickstone can be used on both channels of the base rail.

For a cross-installation of two layers of base rails, XStones are used. These consist of an aluminium block with two pre-assembled Quickstones.

Installing the Quickstone

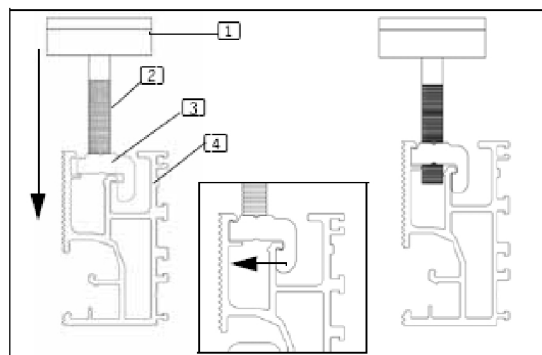

- (1) Element to be fixed (e.g. module clamp)
- (2) Allen bolt
- (3) Quickstone
- (4) Base rail

CAUTION

Material damage through faulty installation

Incorrectly installed Quickstone connections can rip out of the profile.

| Install all Quickstone connections as described below.

Installation

- | If necessary, adjust the bolt so that it does not protrude the Quickstone
- | Fit the Quickstone from above into the profile channel so that it wedges underneath the protruding rail hooks. When fitted correctly, the Quickstone matches' the form of the profile exactly.
- | Tighten the bolt with a torque of 8 Nm.

Installing the X-Stone

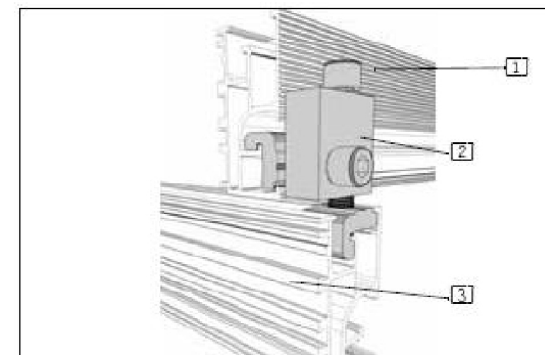

- (1) Horizontal base rail
- (2) X-Stone with 2 Quickstones
- (3) Vertical base rail

Installation

- | Install both Quickstones as described above.
- | Make sure the upper rail lays flat on the lower one.
- | Completely tighten both Quickstones only when you have put the rails in their final position.



When installing on uneven roof surfaces, the use of a special X-stone version is recommended. Please ask your Sales contact for further information.

7.3 Installing the base rails

DANGER

Working on the roof

During work on the roof, parts can drop down or persons may fall off.

| Secure yourself against falling.

| Do not remain in the danger area.

| Wear a hard hat.

| After completing the installation, check that the system and the PV modules are securely fastened.

CAUTION

Damage to tiles through stepping on roof hooks

Do not use fitted roof hooks as a ladder, as this extreme point load could damage the tile below.

Base rails

Depending on the number of modules in one row, the base rails can be of one or of several pieces. The length of the base rail corresponds with the width of the module field. The parts of base rail are inter-connected with joiner pieces.

Telescoping end-piece

The Telescoping end-piece enables you to adjust the overall length of the base rails to the millimeter without the need for on-site cutting.

Joiner piece (1)
Base rail (2)
Telescoping end-piece (3)

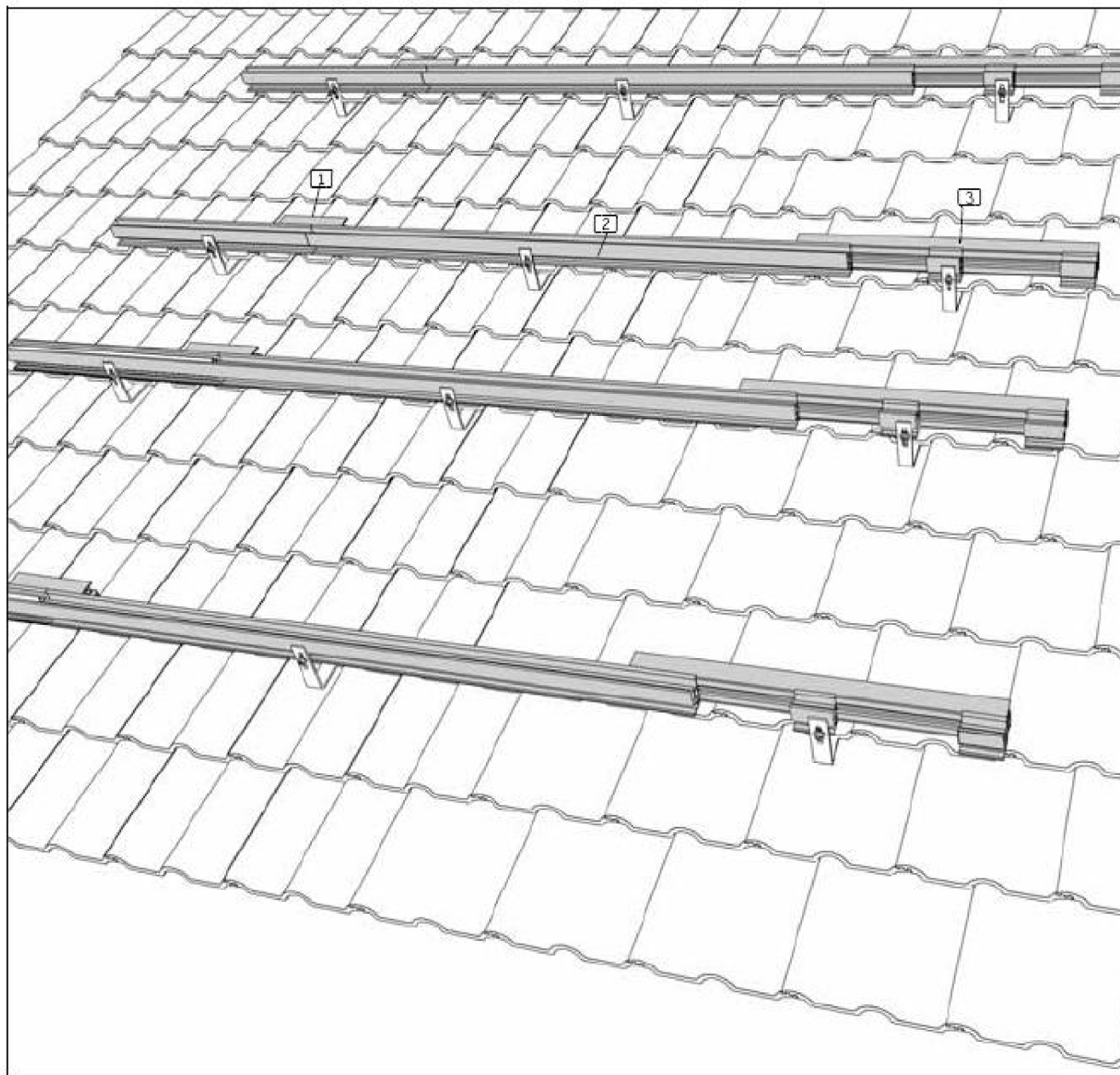

Fixing the base rails

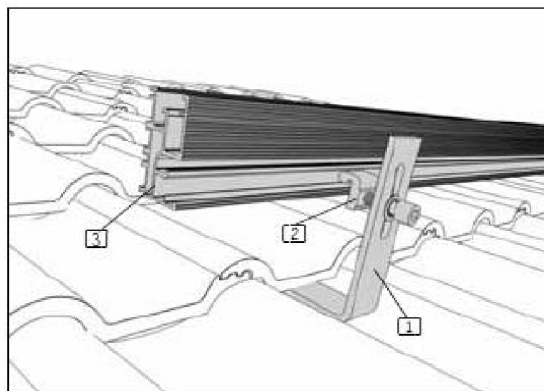

- (1) Roof connection
- (2) Quickstone
- (3) Base rail

Installation:

| The installation is shown with the base rail 13/58
| If your set of rails consists of rails of different lengths, then always begin with the shortest piece.
| Install the rails for each row of modules loosely on the roof hooks, using an M 8x25 mm Allen bolt, washer, retaining washer and Quickstone each (2 to 3 turns of the screw are adequate for loose installation).
| Completely tighten the Quickstones only when you have put the rails in their final position.

Aligning the rails

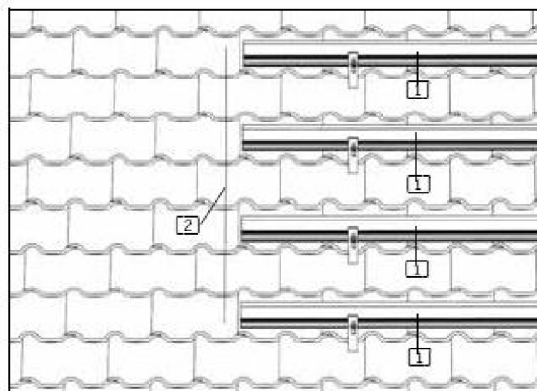

- (1) Base rail
- (2) String or spirit level

Installation:

| Align all rails using a piece of string or a spirit level.
| Tightly fix all Quickstone connections on the rails (tightening torque 8 Nm).



The oblong holes in the roof hooks or L-brackets allow for a height-adjustment of the rails to level out the PV installation on uneven roofs.

Inter-connecting base rails

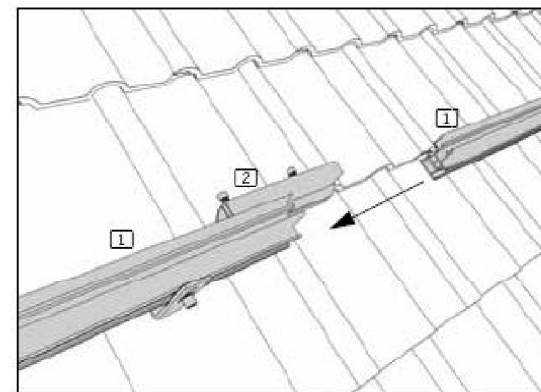

- (1) Base rail
- (2) Joiner piece

Installation:

| Slide the joiner pieces halfway onto the rear side of the base rails.
| Fix the according Allen bolt to the base rail (tightening torque 8 Nm).
| Slide the next rail segment into the Joiner piece.
| Leave a 1cm gap as an extension joint.
| Fix the second Allen bolt to the base rail (tightening torque 8 Nm).



The connected rails should not be longer than 12 meters.

Installing telescoping end-pieces (optional)

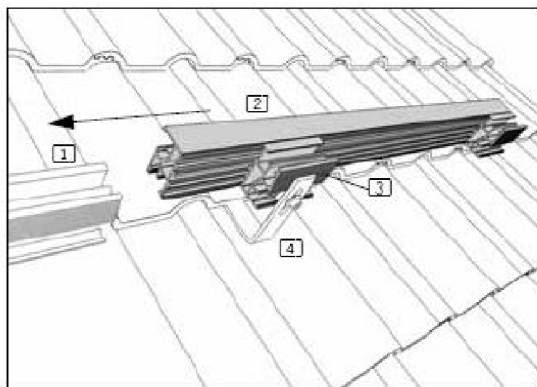

- (1) Base rail
- (2) Telescoping end-piece
- (3) Loose rail section on the telescoping end-piece
- (4) Roof connection

Installation:

- | Mount a telescoping end piece at the end of every row of base rails.
- | If necessary, fix the loose rail section of the telescoping end-piece to a roof connection.



| The telescoping end-piece should not be firmly fixed until the last module of the row is positioned. In that way, the exact necessary length of rail can be realized.

| After adjusting the telescoping end-piece to the last module of a row, fix it completely by tightening the Allen bolt on the rail-side of the telescoping endpiece (tightening torque 8 Nm).

7.4 Installing the modules

DANGER!

Working on the roof

During work on the roof, parts can drop down or persons may fall off.

| Secure yourself against falling.

| Do not remain in the danger area.

| Wear a hard hat.

| After completing the installation, check that the system and the PV modules are securely fastened.

The modules are successively mounted onto the base rails.

It is recommended to start on one side of the module field.

When using telescoping end-pieces, start installing the modules on the rail side of each row, so that the telescoping end-piece can be aligned with the last module to be mounted.

Add anti-slip protection, consisting of a bolt and nut inserted into the holes on the underside of the module frame, to the lowest row of modules (horizontal rail installation only). This keeps the modules from sliding off and thus facilitates installation.

The anti-slip protection does not have any static function in the finished installation.

The modules are fixed with inter-module clamps and endclamps.

An end-clamp will hold one module, an inter-module clamp 2 consecutive ones.

When installing laminates, laminate clamps need to be used instead of module clamps. The installation process is identical. The laminates are set between the rubber lips of the laminate clamps.

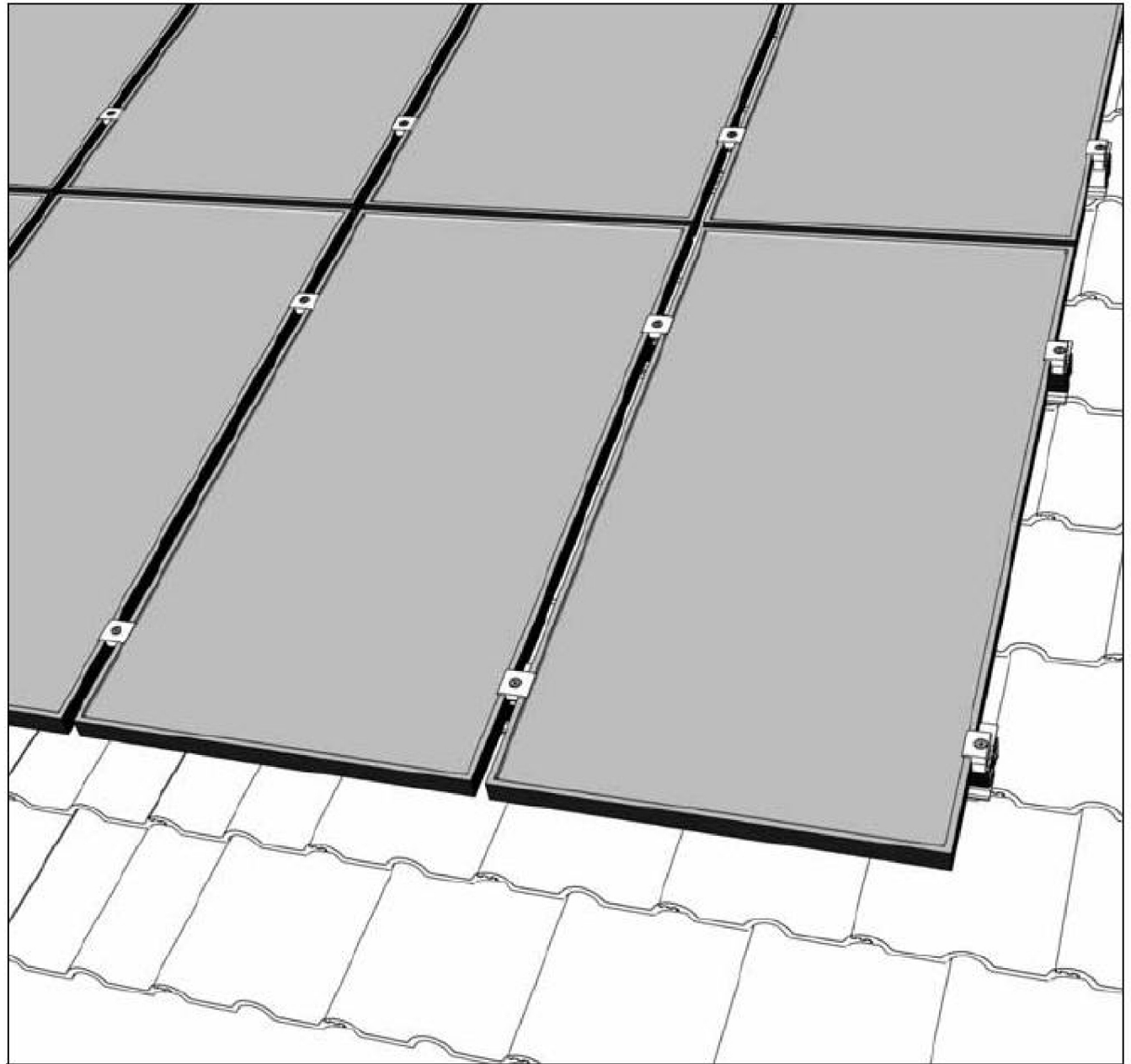

Installing anti-slip protection

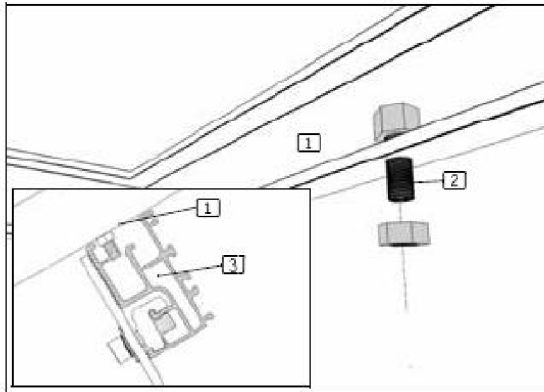

- (1) Module frame (underside)
- (2) Anti-slip protection
- (3) Base rail

Installation:

- | The anti-slip protection is only necessary on the lowermost row of modules.
- | Fit two bolts M6 x 20 and nuts into the lower holes of each module.
- | Place the first module of the bottom row so that the anti-slip protection sits in the rail channel of the lowest row of rails.

Fixing the outer modules of each row

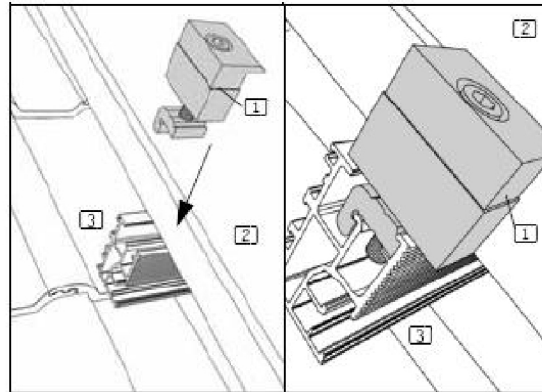

- (1) Module end-clamp with Quickstone
- (2) Module
- (3) Base rail

Installation:

- | Slide the Quickstone into the rail channel.
- | Align the module and push the module end-clamp firmly against the side of the module.
- | Tighten the Allen bolt and Quickstone (tightening torque 8Nm).



When installing laminates, laminate clamps need to be used instead of module clamps. The installation process is identical. The laminates are set between the rubber lips of the laminate clamps.

Fixing the inner modules of each row

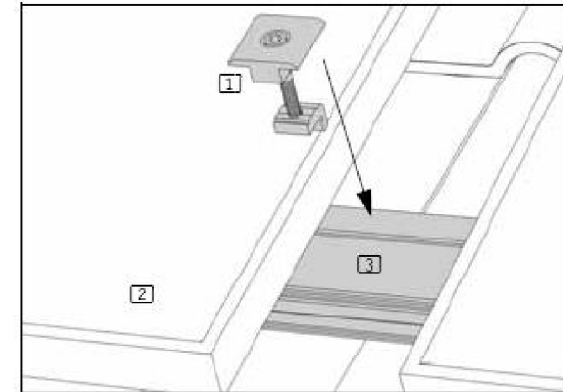

- (1) Inter-module clamp with Quickstone
- (2) Module
- (3) Base rail

Installation:

- | Slide the Quickstone into the rail channel.
- | Push the Inter-module clamp firmly against the already fixed module.
- | Push the next module against the other side of the module-end clamp.
- | Tighten the Allen bolt and Quickstone (tightening torque 8 Nm).



When installing laminates, laminate clamps need to be used instead of module clamps. The installation process is identical. The laminates are set between the rubber lips of the laminate clamps.

Installing further rows of modules

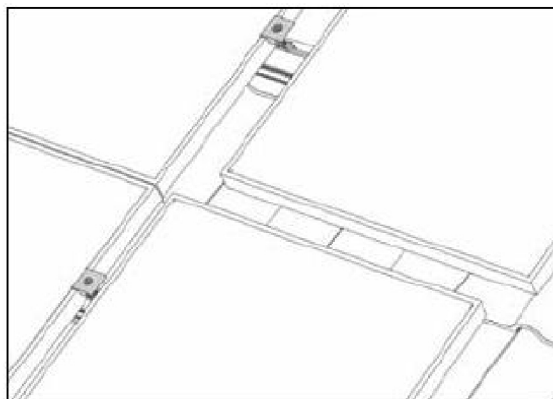

Installation:

| Set the modules of the next row above the lowest row of modules. For optical reasons, a gap can be left between module rows.



Use a spare inter-module clamp as a gauge for the space between module rows. In this way, the horizontal and vertical gaps between modules will be identical.

Fix the modules to the base rails using inter-module clamps and module end-clamps, as described above for the first row of modules.

8 Variation for landscape installation of the modules

DANGER

Working on the roof

During work on the roof, parts can drop down or persons may fall off.

- | Secure yourself against falling.
- | Do not remain in the danger area.
- | Wear a hard hat.
- | After completing the installation, check that the system and the PV modules are securely fastened.

When installing the modules in landscape orientation, the rails need to run vertically.

For most types of roof connections you just turn the preassembled L-bracket by 90°.

For roof connections without L-brackets, cross rail installation can be used. X-stones are used to interconnect two perpendicular layers of rails. Cross rail installation is used, when

- | The roof construction demands a horizontal installation of the base rails while a landscape orientation of the modules is desired, or vice versa.

8.1 Installing base rails vertically

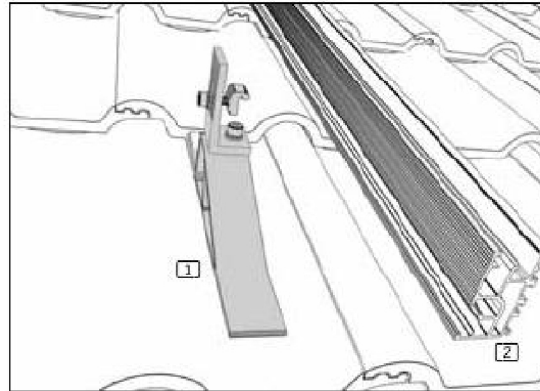

- (1) Roof connection with L-bracket
- (2) Base rail

Installation:

- | If necessary, turn the L-bracket on the roof connection by 90°.
- | Fit the Quickstone into the channel of the base rail and fix it.

8.2 Installing cross rails

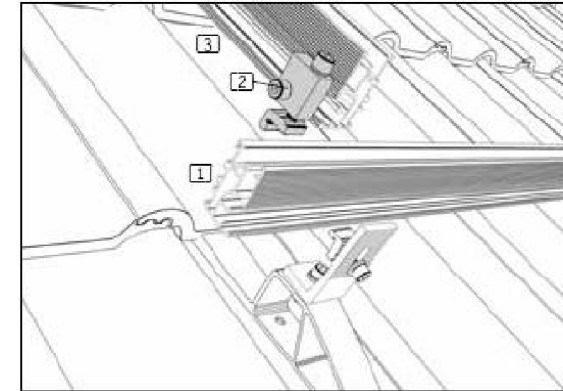

- (1) Horizontal base rail
- (2) X-Stone with 2 Quickstones
- (3) Vertical base rail

Installation:

- | Insert one X-Stone into the side channel of the upper rail.
- | Align the rails.
- | Insert the X-Stones into the top channel of the lower rail.
- | Make sure the upper rail lays flat on the lower one.
- | Fix both Quickstones to the base rails (tightening torque 8 Nm).

